

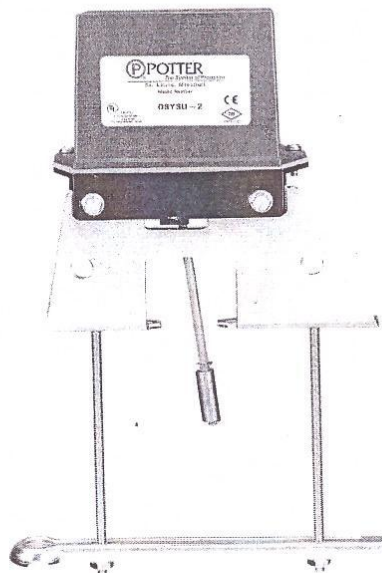

OSYSU-1, -2 OUTSIDE SCREW AND YOKE VALVE SUPERVISORY SWITCH



OSYSU-1 Stock No. 1010106
OSYSU-2 Stock No. 1010206

UL and CSFM Listed, FM Approved, NYMEA Accepted, CE Marked

Dimensions: 6.19"L X 2.25"W X 5.88"H
15,7cm L X 5,7cm W X 14,6cm H

Weight: 2 lbs. (0,9 kg.)

Enclosure: Cover - Die-Cast
Finish - Red Spatter Enamel
Base - Die Cast Zinc
All parts have corrosion resistant finishes.

Cover Tamper: Tamper resistant screws,
Optional cover tamper kit available.

Contact Ratings:
OSYSU-1: One set of SPDT (Form C)
OSYSU-2: Two sets of SPDT (Form C)
15.00 Amps at 125/250VAC
2.50 Amps at 30VDC resistive

Environmental Limitations:

- NEMA 4 and NEMA 6P Enclosure (IP67) when used with appropriate watertight conduit fittings.
- Indoor or Outdoor use (Not for use in hazardous locations. See bulletin no. 5400705 OSYSU-U-EX for hazardous locations.)
- Temperature Range: -40°F to 140°F (-40°C to 60°C)

Conduit Entrances:
2 knockouts for 1/2" conduit provided

Service Use:

Automatic Sprinkler	NFPA-13
One or two family dwelling	NFPA-13D
Residential occupancy up to four stories	NFPA-13R
National Fire Alarm Code	NFPA-72

GENERAL INFORMATION

The OSYSU is used to monitor the open position of an OS & Y (outside screw and yoke) type gate valve. This device is available in two models; the OSYSU-1, containing one set of SPDT (Form C) contacts and the OSYSU-2, containing two sets of SPDT (Form C) contacts. These switches mount conveniently to most OS & Y valves ranging in size from 2" to 12" (50mm to 300mm). They will mount on some valves as small as 1/2" (12,5mm).

The cover is held in place by two tamper resistant screws that require a special tool to remove. The tool is furnished with each device and should be left with the building owner or responsible party. Replacement or additional cover screws and hex keys are available. See ordering information on page 4.

OPTIONAL COVER TAMPER SWITCH

A field installable cover tamper switch is available as an option which may be used to indicate removal of the cover. See ordering information on page 4.

TESTING

The OSYSU and its associated protective monitoring system should be inspected and tested in accordance with applicable NFPA codes and standards and/or the authority having jurisdiction (manufacturer recommends quarterly or more frequently).

FIG. 1 SMALL VALVE INSTALLATION - 1/2" THRU 2 1/2" (12,5mm THRU 63,5mm) SIZES

THESE SWITCHES MOUNT CONVENIENTLY TO MOST 2" TO 12" OS & Y VALVES. THEY WILL MOUNT ON SOME VALVES AS SMALL AS 1/2" (12,5MM). J-HOOKS MAY BE REQUIRED ON VALVES WITH LIMITED CLEARANCE.

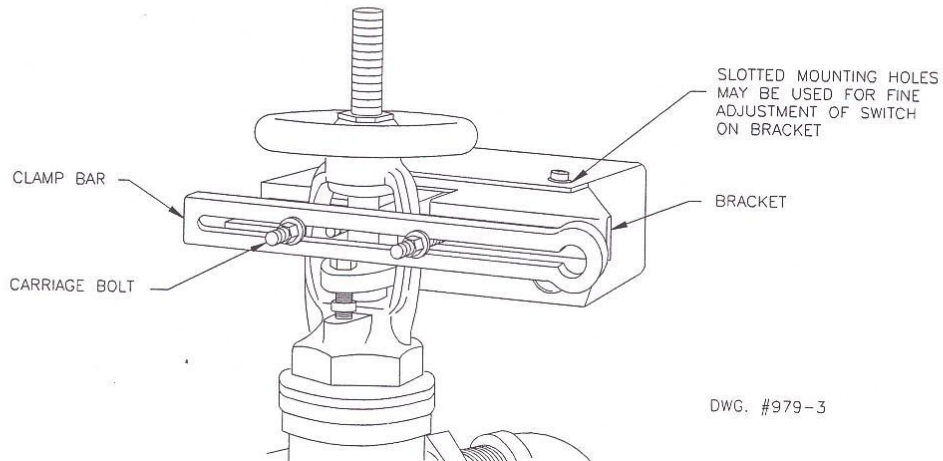

SMALL VALVE INSTALLATION

1. Remove and discard "C" washer and roller from the trip rod.
2. With the valve in the FULL OPEN position, locate the OSYSU across the valve yoke as far as possible from the valve gland, so that the trip rod lays against the non-threaded portion of the valve stem.
3. Loosen the locking screw that holds the trip rod in place and adjust the rod length (see Fig. 4). When adjusted properly, the rod should extend past the valve screw, but not so far that it contacts the clamp bar. Tighten the locking screw to hold the trip rod in place.
NOTE: If trip rod length is excessive, loosen the locking screw and remove the trip rod from the trip lever. Using pliers, break off the 1" (25mm) long notched section (see Fig. 5). Reinstall trip rod and repeat Step 3 procedure.
4. Mount the OSYSU loosely with the carriage bolts and clamp bar supplied. On valves with limited clearance use J-hooks supplied instead of the carriage bolts and clamp bar to mount the OSYSU.
5. Mark the valve stem at the center of the trip rod.
6. Remove the OSYSU. File a 1/8" (3,2mm) deep groove centered on the mark on the valve stem utilizing a 3/16" (4,8mm) round, non-tapered file. Round and smooth the edges of the groove to prevent damage to the valve packing and to allow the trip rod to move easily in and out of the groove as the valve is operated.
7. Mount the OSYSU with the trip rod centered in groove.
8. Final adjustment is made by loosening 2 screws (see Fig. 1) and sliding the OSYSU on the bracket. Adjustment is correct when switches are not activated with the trip rod seated in the valve stem groove and that the switches activate when the trip rod moves out of the groove.
9. Tighten the adjustment screws and all mounting hardware. Check to insure that the rod moves out of the groove easily and that the switches activate within one turn when the valve is operated from the FULL OPEN towards the CLOSED position.
NOTE: CLOSE THE VALVE FULLY TO DETERMINE THAT THE STEM THREADS DO NOT ACTIVATE THE SWITCH. THE SWITCH BEING ACTIVATED BY THE STEM THREADS COULD RESULT IN A FALSE VALVE OPEN INDICATION.

FIG. 2 LARGE VALVE INSTALLATION - 3" THRU 12" (76mm THRU 300mm) SIZES

3" THRU 12" (76mm THRU 300mm) VALVES
USE CARRIAGE BOLTS. BOLTS MOUNT
ON INSIDE OF YOKE, IF THERE
IS SUFFICIENT CLEARANCE.

SLOTTED MOUNTING
HOLES. MAY BE USED
FOR FINE ADJUSTMENT
OF SWITCH ON BRACKET.

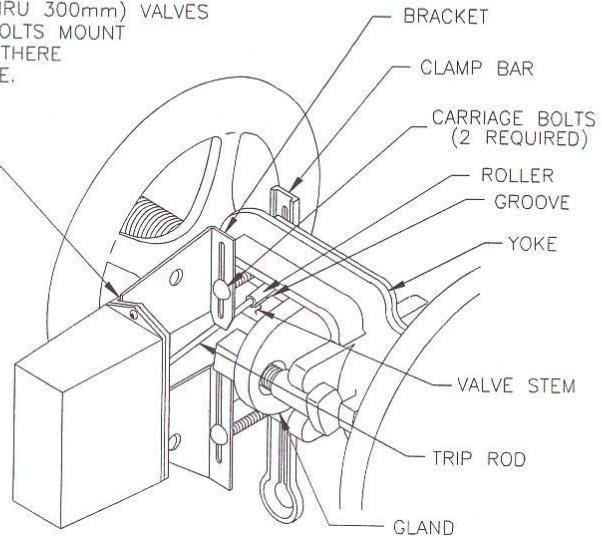

DWG. #979-4

LARGE VALVE INSTALLATION

1. With the valve in the FULL OPEN position, locate the OSYSU across the valve yoke as far as possible from the valve gland, so that the trip rod lays against the non-threaded portion of the valve stem.
2. Mount the OSYSU loosely with the carriage bolts and clamp bar supplied.
3. Loosen the locking screw that holds the trip rod in place and adjust the rod length (see Fig. 4). When adjusted properly, the rod should extend past the valve screw, but not so far that it contacts the clamp bar. Tighten the locking screw to hold the trip rod in place.
NOTE: If trip rod length is excessive, loosen the locking screw and remove the trip rod from the trip lever. Using pliers, break off the one 1" (25mm) long notched section (see Fig. 5). Reinstall trip rod and repeat Step 3 procedure.
4. Mark the valve stem at the center of the trip rod.
5. Remove the OSYSU. File a 1/8" (3,2mm) deep groove centered on the mark of the valve stem utilizing a 3/8" (9,5mm) round,

- non-tapered file. Round and smooth the edges of the groove to prevent damage to the valve packing and to allow the trip rod to move easily in and out of the groove as the valve is operated.
6. Mount the OSYSU loosely with the trip rod centered in groove.
7. Final adjustment is made by loosening 2 screws (see Fig. 2) and sliding the OSYSU on the bracket. Adjustment is correct when switches are not activated with the trip rod seated in the valve stem groove and that the switches activate within one turn when the valve is operated from the FULL OPEN towards the CLOSED position.
8. Tighten the adjustment screws and mounting hardware. Check to insure that the rod moves out of the groove easily and that the switches activate within one turn when the valve is operated from the FULL OPEN towards the CLOSED position.

NOTE: CLOSE THE VALVE FULLY TO DETERMINE THAT THE STEM THREADS DO NOT ACTIVATE THE SWITCH. THE SWITCH BEING ACTIVATED BY THE STEM THREADS COULD RESULT IN A FALSE VALVE OPEN INDICATION.

FIG. 3

DIMENSIONS

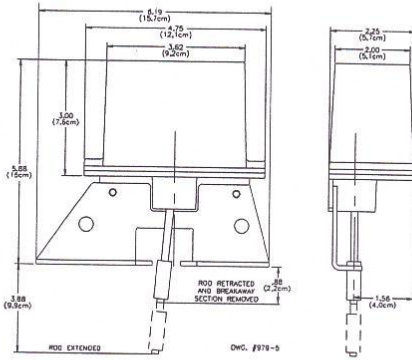
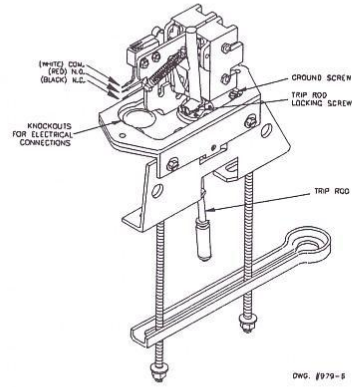

FIG. 4

PARTS



BREAKING EXCESSIVE ROD LENGTH

FIG. 5

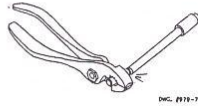

SWITCH TERMINAL CONNECTIONS CLAMPING PLATE TERMINAL

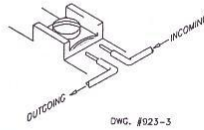

CAUTION:
An uninsulated section of a single conductor should not be looped around the terminal and serve as two separate connections. The wire must be severed, thereby providing supervision of the connection in the event that the wire becomes dislodged from under the terminal.

TYPICAL ELECTRICAL CONNECTIONS

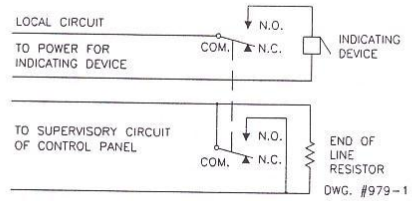

Contacts shown in normal (valve open) condition.

TYPICAL SWITCH ACTION

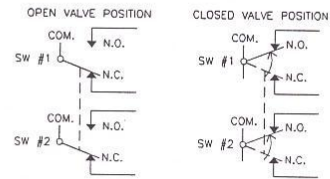

DWG. #979-2

ORDERING INFORMATION

MODEL	DESCRIPTION	STOCK NO.
OSYSU-1	Outside Screw & Yoke-Supervisory Switch (Single switch)	1010106
OSYSU-2	Outside Screw & Yoke-Supervisory Switch (Double switch)	1010206
--	Cover Screw	5490344
--	Hex Key for Cover Screws and Installation Adjustments	5250062
--	Optional Cover Tamper Switch Kit	0090131

For pressure reducer type valve installation kits (if required) contact valve manufacturer.